

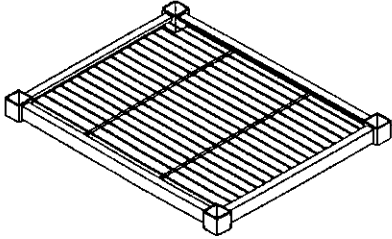







Assembly Instructions for Three Shelf Equipment Stand No. ES735

NO.	DESCRIPTION	Q'TY	NO.	DESCRIPTION	Q'TY
A		3	C		12
			D		4
			E		4
B		4	F		2
			G		2

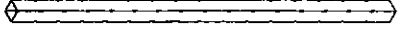
Assembly Instructions

1. Lay out all parts to be certain that you have the right parts and the correct number of each.
2. Put Part E into the end of each Part B.
3. Place Part C onto the leg (Part B), make certain it is in the same notch on each leg. The narrow part must be towards the top of the leg.
4. Insert each leg into the shelf (Part A) with the widest part of each shelf corner facing towards the bottom of the leg (Part B).
5. Repeat 3 and 4 for the remaining two shelves.
6. When all three shelves have been installed, put Part D into the top of each leg.
7. Turn the table upside down and install the casters Parts F and G. Make certain the two casters with the locking brake (Part F), are on the two front legs or the two side legs.
8. Return the unit to its upright position and it is ready for use.

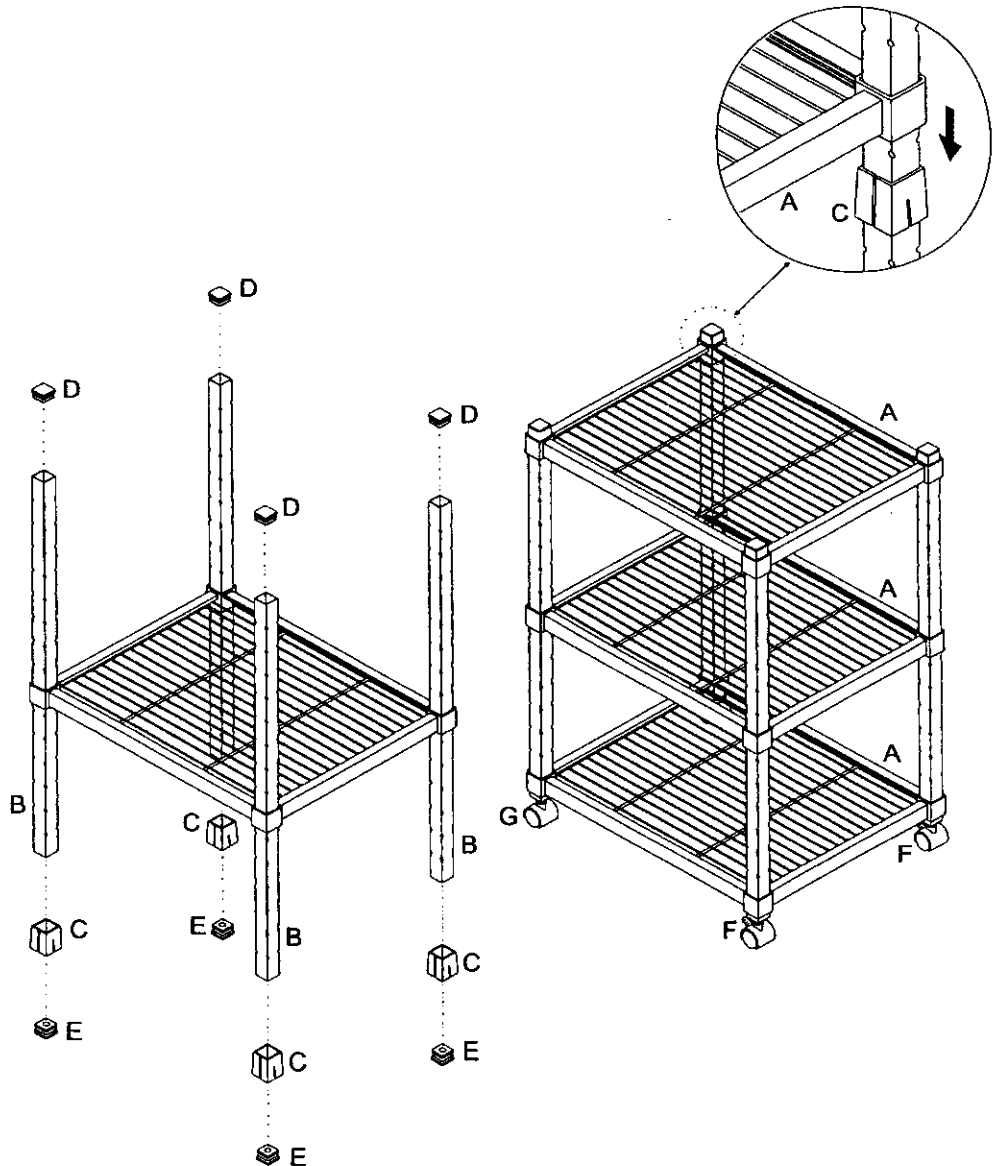

Alvin & Company, Inc.

Bloomfield, CT

Grand Prairie, TX